



FORD CONNECT L1

raaco van equipment is Danish first class quality and design!

raaco van equipment is made of lightweight aluminium and is built up from a variety of flexible modules, which are easily installed in the van. You can choose between raaco standard modules or a customized solution, which is made to suit your exact needs.

A wide range of bins and assortment boxes are available for each module, made from robust, high grade plastic. The system gives you a quick overview and direct access to the contents, so you can work effectively throughout the day.

With raaco van equipment you get a robust, durable solution for your mobile workplace.



MODEL S7 – alternative

Content: 8 pcs. 4-800
2 pcs. Bins
1 pcs. Perforated panel

Total weight: 32,1 kg

Total EAN: 183062

S7 weight 32,1 kg

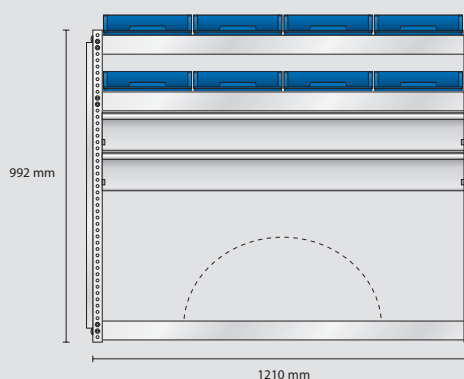

MODEL S9 – alternative

Content: 1 pcs. Perforated panel

Total weight: 18,5 kg

Total EAN: 183086

S9 weight 18,5 kg

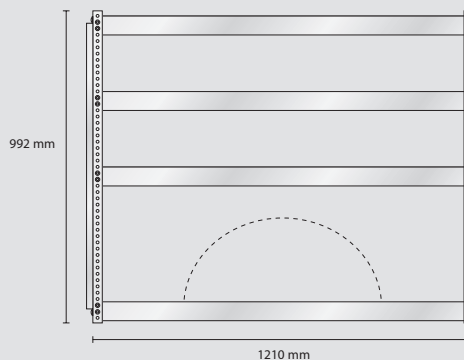

FORD CONNECT L1

MODEL S1 – standard

Content: 10 pcs. 6-1100
 4 pcs. 8-2000
 1 pcs. Perforated panel

Total weight: 28,5 kg

Total EAN: 183000

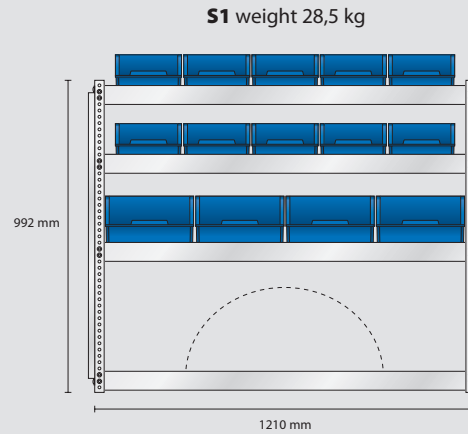

MODEL S3 – electrician

Content: 1 pcs. 4-800
 12 pcs. 5-600
 2 pcs. CarryLite 80-15
 1 pcs. Perforated panel

Total weight: 27,9 kg

Total EAN: 183024

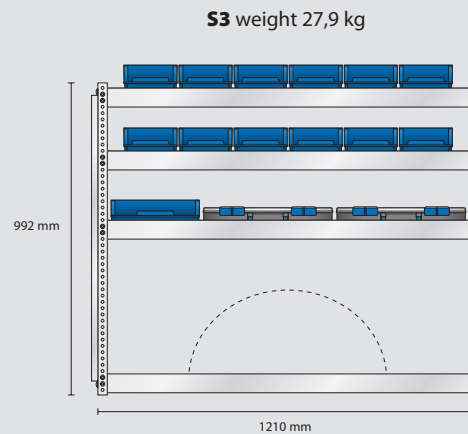

MODEL S5 – plumber

Content: 12 pcs. 4-800
 1 pcs. Perforated panel

Total weight: 25,7 kg

Total EAN: 183048

