



MERCEDES VITO L3

raaco van equipment is Danish first class quality and design!

raaco van equipment is made of lightweight aluminium and is built up from a variety of flexible modules, which are easily installed in the van. You can choose between raaco standard modules or a customized solution, which is made to suit your exact needs.

A wide range of bins and assortment boxes are available for each module, made from robust, high grade plastic. The system gives you a quick overview and direct access to the contents, so you can work effectively throughout the day.

With raaco van equipment you get a robust, durable solution for your mobile workplace.

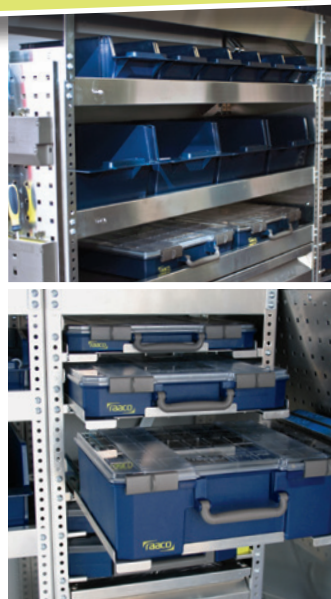

MODEL AS17 – alternative

- Content: 12 pcs. 4-800
- 15 pcs. 6-1100
- 8 pcs. 8-2000
- 3 pcs. Bins
- 3 pcs. Perforated panels

Total weight: 103 kg

Total EAN: 182430

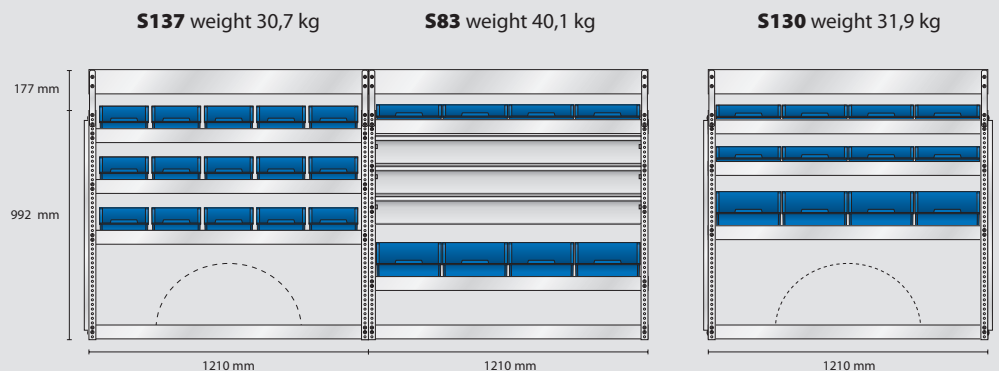

MODEL AS18 – alternative

- Content: 3 pcs. Perforated panels

Total weight: 64,8 kg

Total EAN: 182447

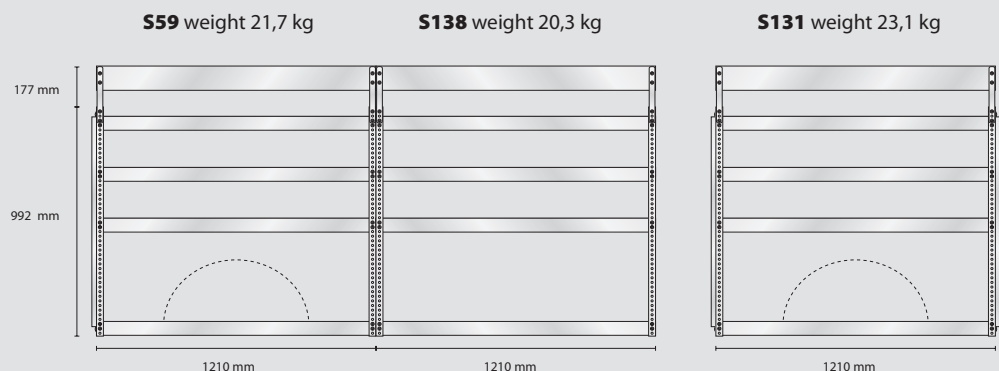

MERCEDES VITO L3

MODEL SS9 – standard

Content: 12 pcs. 5-600
 25 pcs. 6-1100
 8 pcs. 8-2000
 2 pcs. Perforated panels

Total weight: 91,2 kg

Total EAN: 182409

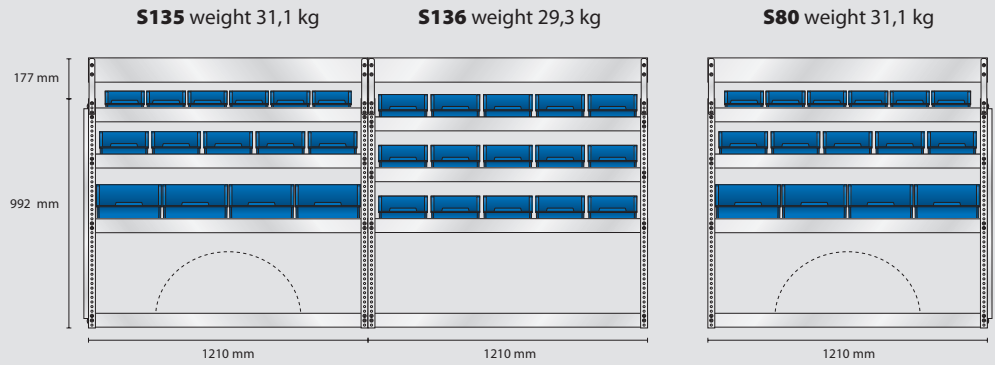

MODEL ES9 – electrician

Content: 26 pcs. 4-800
 4 pcs. CarryLite 80-15
 1 pcs. Bin
 2 pcs. Perforated panels

Total weight: 95,3 kg

Total EAN: 182416

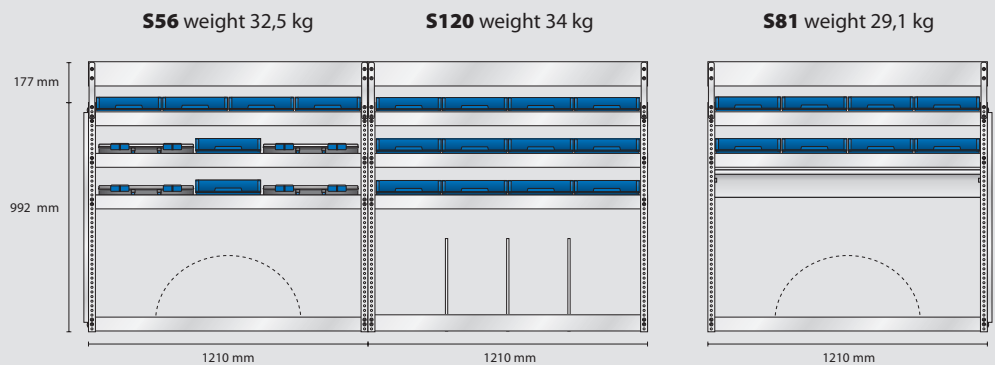

MODEL VS9 – plumber

Content: 32 pcs. 4-800
 4 pcs. 8-2000
 1 pcs. Bin
 2 pcs. Perforated panels

Total weight: 92 kg

Total EAN: 182423

